

Nice

BiDi-Awning

CE

Exterior bidirectional interface for tubular motor

EN - Instructions and warnings for installation and use

1 WARNINGS AND GENERAL PRECAUTIONS

- **⚠ CAUTION! – This manual contains important instructions and warnings for personal safety.**
Read carefully all parts of this manual.
If in doubt, suspend installation immediately and contact the Nice Technical Assistance.
- **⚠ CAUTION! – Important instructions: keep this manual in a safe place to enable future product maintenance and disposal procedures.**
- **⚠ CAUTION! – All installation and connection operations must be performed exclusively by suitably qualified and skilled personnel with the unit disconnected from the mains power supply.**
- **⚠ CAUTION! – Any use other than that specified herein or in environmental conditions other than those stated in this manual is to be considered improper and is strictly forbidden!**
- The products packaging materials must be disposed of in full compliance with local regulations.
- Never modify any parts of the device. Operations other than those specified can only cause malfunctions. The manufacturer declines all liability for damage caused by makeshift modifications to the product.
- Never place the device near the sources of heat and never expose it to naked flames. These actions can damage the product and cause malfunctions.
- This product isn't intended for use by people with reduced physical, sensory or mental capabilities (including children) or who lack experience and knowledge, unless they have been supervised or instructed to use the product by a person responsible for their safety.
- Make sure that children don't play with the product.
- Check the warnings in the instruction manual for the motor that the product is connected to.
- Handle the product with care, don't crush, knock or drop it to avoid damage.

2 PRODUCT DESCRIPTION

The BiDi-Awning control unit enables the control of a mains-powered, single-phase asynchronous motor with connection types: Down, Common, Up, used for the automation of awnings, rolling shutters and similar.

The BiDi-Awning control unit incorporates a radio transceiver operating at the frequency of 433.92 MHz with the rolling code technology to guarantee optimal safety levels.

Each control unit can memorise up to 30 mono or bidirectional transmitters in the series ERA, ERGO, FLOR, NICEWAY and DOMI, which enable the remote control of the unit.

In these 30 transmitters, climatic radio sensors can be memorised, for the automatic control of the control unit according to weather conditions. The control unit is equipped with overload, and overheating protection, which can disable the relays to prevent damage to the circuit.

3 TECHNICAL SPECIFICATIONS

BiDi-Awning is produced by Nice S.p.A.

Warning

All technical specifications stated in this section refer to an ambient temperature of 20 °C (± 5 °C). Nice S.p.A. reserves the right to modify the product at any time when necessary, while maintaining the same functionalities and intended use.

Table A1 - BiDi-Awning - Specifications	
Type	Operating control unit for an electric motor
Construction of control	Independently mounted control
Power supply	100–240 V AC, 50/60 Hz
Motor rated current	2 A
Motor rated power	480 VA for Vn = 240 V; 460 VA for Vn = 230 V; 240 VA for Vn = 120 V; 200 VA for Vn = 100 V
Supply Connection	External conductor
Recommended wires cross-section	0.5–4 mm ² for 1 wire; 0.5–1.5 mm ² for 2 wires
Overvoltage category	II
Rated impulse voltage	2500 V
Pollution degree	2
Protection against electric shock class	Class I control
Casing protection rating	IP 55
Operating temperature	-20 °C .. +50 °C
Shipping and storage temperature	-20 °C .. +50 °C
Dimensions (mm)	98 x 26 x 20
Weight	45 g

Table A2 - BiDi-Awning - Radio transceiver	
Frequency band	433.05–434.04 MHz
Code	OPERA/FLOR (rolling code), PLN2+ (rolling code)
No. of memorisable transmitters	30, including climatic sensors
Transceiver range	Estimated at 150 m in open space and 20 m inside buildings (*)
Max. transmit power	10 dBm

(*) The transceiver range is strongly influenced by other devices operating at the same frequency with continuous transmission, such as alarms and radio headphones which interfere with the control unit transceiver.

4 INSTALLATION



- The product is subject to hazardous electric voltages
- The installation of the BiDi-Awning and automations must be performed exclusively by technically qualified personnel, in observance of current legislation and standards, and according to these instructions. All connections must be made with the system disconnected from the power supply.
- The BiDi-Awning control unit was designed for insertion in a junction box or wall box; its housing doesn't have any protection against water and has only basic protection against contact with solid parts. Never place BiDi-Awning in inadequately protected environments.
- Never open or perforate the BiDi-Awning housing. These actions are subject to hazardous electric voltages!
- The power supply line must be protected by suitable magneto-thermal (rated up to 16 A) and residual-current circuit breakers.
- The control unit can be fitted with double-sided tape directly in the shutter/awning box. To avoid the risk of water leaks it should be positioned with the cables towards the bottom. Don't place the control unit with the cables towards the top.

1. Switch off the mains power supply (Figure 1).
2. Open the container by removing the sealing cap (Figure 2).
3. Thread the two cables through the designated holes in the sealing cap (Figure 3).
4. Strip the motor cable and the power supply cable about 3 cm and then the single wires approx. 6 mm (Figure 4).
5. Pull the board a few centimetres out of the container (Figure 5).
6. Connect the wires to the terminals according to Figure 8 and chapters 4.1, 4.2 and 4.3.
7. Push the board inside the container. Make sure that the stripped length of the cable is fully inside the container (Figure 6).
8. Slide the sealing cap until the container closes completely (Figure 7).

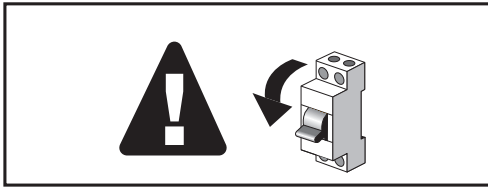

Figure 1: Mains switch

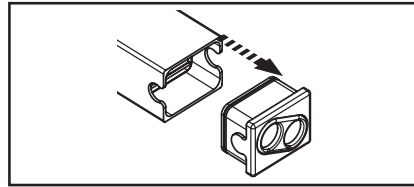

Figure 2: Sealing cap on the container

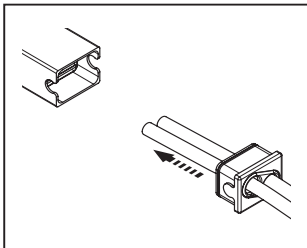

Figure 3: Sealing cap on the container

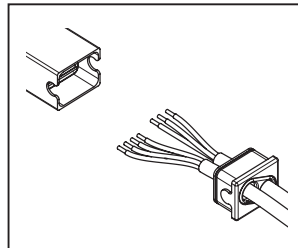

Figure 4: Motor cable and power supply cable

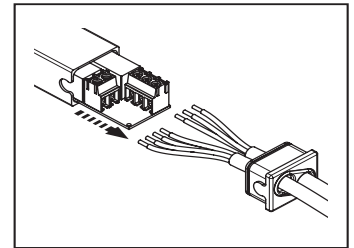

Figure 5: Board pulled out of the container

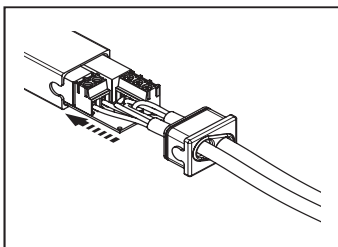

Figure 6: Wires to terminals connection

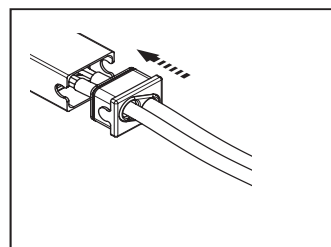

Figure 6: Board to container insertion

4.1 - Electrical connections

⚠ ⚠ CAUTION! – Risk of electric shock !

Carefully follow all the connection instructions.

If you have any questions, concerns or need additional product knowledge, visit the website: www.niceforyou.com, where you can find all the current technical data.

An incorrect connection can be dangerous and cause damage to the system.

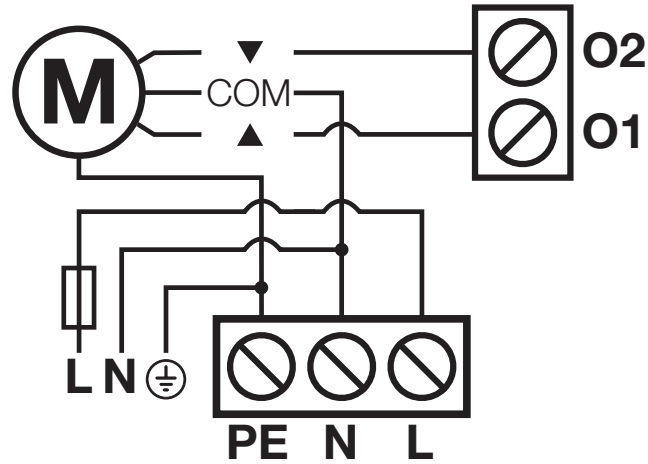

Figure 8: Electrical connections

4.3 - Motor connection

The single phase asynchronous motor must be connected to the mains using terminals O1-N-O2-PE (Up, Common, Down, Grounding). Up corresponds to the key ▲ (direction of wind speed sensor activation) of the transmitters, Down corresponds to key ▼ (by default for direction of sun sensor activation). If after connecting the direction of motor rotation is incorrect, exchange the connections of terminals O1 and O2.

⚠ CAUTION! – Never connect more than one motor per control unit!

4.4 - Power supply

The electric power supply of the control unit must be connected using terminals L-N-PE (Line, Neutral, Grounding).

The BiDi-Awning control unit can operate with supply voltage of 100 to 240 Volts and frequency of 50 or 60 Hz.

5 MEMORISING TRANSMITTERS

This chapter describes the memorisation procedures in Mode I, used to control a single automation with 3 keys of transmitters, and Mode II, used to control an automation with a single key, thus leaving other keys free to control other automations.

- The key ■ corresponds to the central key of the transmitters ERGO, PLANO and NICEWAY.
- All memorisation sequences are timed. They need to be completed within the set time limits.
- In case of transmitters, which can be assigned to groups (for example ERA P6BD) using BiDi interface, you need to select the relevant group before starting memorisation procedure.
- Settings with a radio are possible on all receivers located within the operating radius of the transmitter, and therefore only the device required for the operation should remain powered

⚠ CAUTION! – The first memorised transmitter needs to be equipped with a programming key (PROG/PRG), otherwise the programming of the control unit functions isn't possible.

5.1 - Mode I

In Mode I the command associated with the transmitter keys is set (Table A3). In Mode I only one memorisation phase is performed for each transmitter and only one memory location is occupied. During memorisation in Mode I it isn't important which key is pressed on the transmitter.

Key	Command
The ▲ key or the 1 st channel	Up
The ■ key or the 2 nd channel	Stop
The ▼ key or the 3 rd channel	Down







5.2 - Memorising transmitters in Mode I

When there is no transmitter memorised, the first one can be memorised during a startup phase according to the following procedure.

N°	Description	Example
1.	Connect the control unit to the power mains, which is confirmed by 2 beeps.	
2.	Within 10 seconds: <ul style="list-style-type: none"> • Monodirectional transmitters: press and hold any key of the transmitter for at least 3 seconds to be memorized • Bidirectional transmitters: press any key of the transmitter to be memorized 	MONO: BIDI:
3.	If the memorisation procedure is successful, you hear 3 beeps.	

If no transmitters are memorized during the startup phase, the programming procedure ends automatically after 10 seconds, which is signalled with one long beep.

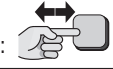
The transmitters can be memorised with the programming pushbutton according to the following procedure.

Table A5 - BiDi-Awning - Memorising other transmitters in Mode I		
N°	Description	Example
1.	Press the programming key of the already memorised transmitter.	
2.	Wait until you hear 2 beeps.	
3.	Press the ▼ key (or the 3 rd channel) to enter the programming mode, which is signalled hear 2 beeps.	
4.	Within 10 seconds: <ul style="list-style-type: none"> • Monodirectional transmitters: press and hold any key of the transmitter to be memorized for at least 3 seconds. • Bidirectional transmitters: press any key of the transmitter to be memorized. 	MONO:  3s BIDI: 
5.	If the memorisation procedure is successful, you hear 3 beeps.	
6.	Repeat steps 4 and 5 to acquire all the remotes.	
7.	If the device doesn't receive any signal for 10 seconds, the programming procedure ends automatically.	

5.3 - Mode II

In Mode II each key of the transmitter can be associated with one of 10 possible commands (Table A6). For example, one automation can be controlled with just one key memorised for the Step-by-step command, while the other keys are left free to control other automations.

In Mode II one memorisation phase is performed for each key and each occupies one location in the memory. During Mode II memorisation, the key which is pressed is memorised.







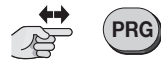

If another key is to be assigned a command on the same transmitter, a new memorisation phase needs to be performed for that specific key.

⚠ CAUTION! – For the partial positions to work correctly, you need to perform the calibration procedure (see chapter 6.1).

Table A6 - BiDi-Awning - Memorisation in Mode II	
N°	Command
1	Step-by-step (Up-Stop-Down-Stop...)
2	Go to position level 5%
3	Go to position level 25%
4	Go to position level 50%
5	Go to position level 75%
6	Up
7	Down
8	Stop
9	“Hold-to-run” Down*
10	“Hold-to-run” Up*

* “Hold-to-run” command isn't available in some transmitters.

5.4 - Memorising transmitters in Mode II

Table A7 - BiDi-Awning - Memorising first and other transmitters in Mode II		
N°	Description	Example
1.	Press the programming key of the already memorised transmitter.	
2.	Wait until you hear 2 beeps.	
3.	Press the programming key the number of times required for a particular command 1 = Step-by-Step, 2 = go to position level 5%, 3 = go to position level 25%, 4 = go to position level 50%, 5 = go to position level 75%, 6 = Up, 7 = Down, 8 = Stop, 9 = Hold-to-run Down, 10 = Hold-to-run Up.	1-10 
4.	Make sure the interface emits the correct number of beeps corresponding to the desired command.	1-10 
5.	Within 10 seconds: • Monodirectional transmitters: press and hold the required key of the transmitter for at least 3 seconds to be memorized. • Bidirectional transmitters: press the required key of the transmitter to be memorized	MONO:  BIDI: 
6.	If the memorisation procedure is successful, you hear 3 beeps.	
7.	Repeat steps 5 and 6 to acquire all the remotes with the same command.	
8.	Repeat steps 3 to 6 to acquire all the remotes with another command.	
9.	If the device doesn't receive any signal for 10 seconds, the programming procedure ends automatically. You hear one long beep.	





Note.

If the memory is full (30 transmitters memorised) you hear 6 beeps and the transmitter can't be memorised.

5.5 - Memorising a new transmitter using an enabling code of an already memorised transmitter

The bidirectional transmitter has an enabling code. By transferring this code from a memorized transmitter to a new transmitter, the latter is recognized and memorized automatically by the control unit. Please refer to the manual of the transmitters for further details.

⚠ CAUTION! – The enabling code can only be transferred between two transmitters that have the same radio coding.

Table A8 - Mono and bi-directional transmitters - transmitting enabling code		
N°	Description	Example
1.	Put a previously memorised transmitter close to a new one.	
2.	On the new transmitter press the command key. The LED of the previously memorised transmitter switches on and starts flashing.	New:  Old: 
3.	Press command key on the previously memorised transmitter.	Old: 
4.	When the code has been transferred, for an instant both transmitters vibrate and the green LED illuminates signalling end of the procedure. When the new transmitter is used for the first 20 times it transmits the enabling code to the receiver together with the command. The receiver memorizes automatically the identification code of the transmitter that sent it.	

6 SETTINGS





6.1 - Calibration

During the calibration process the device learns the position of the Up and Down limit positions. The calibration can be performed automatically or manually. During the automatic calibration the motor performs the Up, Down and Up movements to recognize the limit positions. During the manual calibration, limit positions need to be saved manually while the motor performs the Up and Down movements.









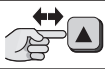

⚠ CAUTION! – If the automatic calibration didn't recognize properly the limit positions, perform the manual calibration instead.

⚠ CAUTION! – There is a fixed operation time of 240 s when module isn't calibrated.

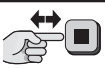
To perform automatic calibration, follow the steps from the table below:

Table A9 - BiDi-Awning - Automatic calibration		
N°	Description	Example
1.	The programming procedure ends automatically when you hear one long beep.	
2.	Wait until you hear 2 beeps.	
3.	Briefly press the ■ key (or the 2 nd channel) of the memorised transmitter.	
4.	The motor completes the Up, Down and Up movement automatically.	
5.	The programming procedure ends automatically after finishing 2 complete movement. You hear one long beep.	

To perform calibration manually, follow the steps from the table below. Perform manual calibration only when automatic doesn't work.

Table A10 - BiDi-Awning - Manual calibration		
N°	Description	Example
1.	Press the PRG programming button of the previously memorised transmitter.	
2.	Wait until you hear 2 beeps.	
3.	Press the key ▲ (or the first channel) of the transmitter to start calibration.	
4.	The device starts the Up movement	
5.	Press the ■ key (or the second channel) of the transmitter to set the Up limit position.	
6.	The device starts the Down movement.	
7.	Press the ■ key (or the second channel) of the transmitter to set the Down limit position.	
8.	The device starts the Up movement.	
9.	Press the ■ key (or the second channel) of the transmitter to set the Up limit position.	
10.	The programming procedure ends automatically, which is signalled with a long beep.	

Note.

It's possible to activate calibration with transmitters without the PRG programming button:

1. Press the ▲ + ■ + ▼ keys at the same time.
2. Wait until you hear 2 beeps.
3. Confirm with the ■ key.
4. Motor will perform two full movements for calibration.

6.2 - Partial positions

The BiDi-Awning control unit enables setting quickly accessible partial positions. Partial positions work only with transmitters memorized in Mode I.

Table A11 - BiDi-Awning - Available partial positions		
N°	Press at the same time to activate	Default position
1.	The ▲ and ▼ keys The 1 st and 3 rd channel	50% of the moving time
2.	The ▲ and ■ keys The 1 st and 2 nd channel	15% of the moving time



- If the Venetian blind mode is activated (see chapter 6.4), the Venetian blinds stop at 15% and the slats are rotated by 10% by default (the 2nd partial position changes operation).
- If the Venetian blinds mode is disabled, the shutter stops at 15% (the 2nd partial position) by default.
- The partial positions work if the calibration was performed.

To set a new position for the 1st partial position, follow the steps from the table below:



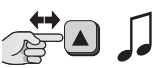

Table A12 - BiDi-Awning - Setting 1st partial position		
N°	Description	Example
1.	Press the programming PRG key of the already memorised transmitter.	
2.	Wait until you hear 2 beeps.	
3.	Press the ▲ and ▼ keys (or the first and third channel) at the same time to enter the programming mode. You hear 2 beeps.	
4.	Bring the shutter/blind/awning at your desired partial position (or press the ▲ and ▼ keys or the 1 st and 3 rd channel at the same time to disable the 1 st partial position).	
5.	Save and end the programming by pushing the programming PRG pushbutton. You hear one long beep.	

To set a new position for the 2nd partial position, follow the steps from the table below:

Table A13 - BiDi-Awning - Setting 2nd partial position		
N°	Description	Example
1.	Press the programming PRG key of the already memorised transmitter.	
2.	Wait until you hear 2 beeps.	
3.	Press the ▲ and ■ keys (or the 1 st and 2 nd channel) at the same time to enter the programming mode. You hear 2 beeps.	
4.	Bring the shutter/blind/awning at your desired partial position (or press the ▲ and ■ keys or the 1 st and 2 nd channel at the same time to disable the 2 nd partial position).	
5.	Save and end the programming by pushing the programming pushbutton. You hear one long beep.	

6.3 - Virtual Limit Switch









If needed, you can set a virtual limit switch, limiting the shutter/blind/awning movement to the specified position (range).

Table A14 - BiDi-Awning - Setting virtual limit switch		
N°	Description	Example
1.	Bring the shutter/blind/awning to your desired position (the virtual limit switch position).	
2.	Press the programming key of the already memorized transmitter.	
3.	Wait until you hear 2 beeps.	
4.	Press and hold the ▲ key (or the 1 st channel) for 2 seconds until you hear 1 long beep to confirm the programmed position. • If the buzzer makes 5 short beeps, BiDi-Awning wasn't calibrated before.	
5.	Press the key of the transmitter to select the limit you want to keep as reference: • the ▲ key or the 1 st channel - the top limit is your reference limit switch, • the ▼ key or the 3 rd channel - the bottom is your reference limit switch.	
6.	The motor makes a move between the virtual and mechanical limit switch.	
7.	The programming procedure ends automatically.	

6.4 - Venetian blinds

The BiDi-Awning control unit enables controlling slats for Venetian blinds. When the Venetian blinds control is enabled, pressing the ▲ key/ the 1st channel or the ▼ key / the 3rd channel moves the slats by 20%. The normal Up and Down movement needs to be performed by pressing and holding the corresponding keys. Time of full slats movement needs to be adjusted for the function to work properly. By default, the Venetian blinds function is disabled and the full movement time is set to 1.5 s.

To enable or disable the Venetian blinds control and set the slats movement time, follow the steps from the table below:

Table A15 - BiDi-Awning - Setting Venetian blinds behavior		
N°	Description	Example
1.	Press the programming PRG key of the already memorised transmitter.	
2.	Wait until you hear 2 beeps.	
3.	Press the keys ▼ and ■ (or the 2 nd and 3 rd channel) at the same time to enter the programming mode.	
4.	If after 5 sec. the buzzer emits 2 beeps, the Venetian blinds mode is enabled, if it emits 1 beep the Venetian blinds mode is disabled.	
5.	Press key ▲ (or the 1 st channel) of the transmitter to toggle the setting, the buzzer informs about the current setting: • 2 beeps – Venetian blinds control enabled • 1 beep – Venetian blinds control disabled	
6.	Press the programming key the number of times corresponding to the required time 1 = 250ms, 2 = 500ms, 3 = 750ms, 4 = 1s, 5 = 1.25s, 6 = 1.5s, 7 = 1.75s, 8 = 2s, 9 = 2.25s, 10 = 2.5s, 11 = 2.75s, 12 = 3s.	
7.	Check that the buzzer sounds with number of beeps corresponding to the required time.	
8.	If the device doesn't receive any signal for 10 seconds, the programming procedure ends automatically. You hear one long beep.	

6.5 - Climatic sensors

The control unit supports Nice radio mono and bidirectional climatic sensors. Memorisation of a climatic sensor needs to be carried out like that of a normal transmitter (follow the procedure in Table A5). Thresholds for commands needs to be programmed on the climatic sensor.

Commands connected to wind are given priority, followed by the sun and rain commands. Please refer to the manual of the climatic sensor for further details.

Reactions to the sun can be activated/deactivated using the Sun ON/OFF button on the transmitter (by default reactions are activated).

Table A16 - BiDi-Awning - Responses to climatic commands	
Command	Response
Sun ON	Down (default) / the partial position (if set).
Sun OFF	Go to the Up position.
Rain ON	Down (default) / Up. (possible to configure with settings - see description below).
Rain OFF	If RAIN ON moves motor DOWN then RAIN OFF moves motor UP. If RAIN ON moves motor UP then RAIN OFF doesn't trigger any action (the motor doesn't move).
Wind ON	Go to the Up position and block the motor.
Wind OFF	Unlock the motor control for wind ON.

Note.

60 minutes timeout of alarm condition is set when the climatic sensor is missing.

Note.

Disable alarm condition - Within 60 seconds, movement attempt is performed twice.

4 short beeps are performed and the motor is unlocked.

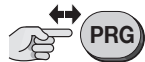







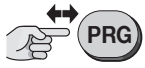





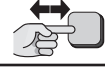

Table A17 - BiDi-Awning - Setting response to Sun ON command		
N°	Description	Example
1.	Press the programming PRG key of the already memorised transmitter.	
2.	Wait until you hear 2 beeps.	
3.	Press and hold the  key (or the 2 nd channel) for 2 seconds until you hear 1 long beep.	
4.	Press the key of the transmitter to select response to the Sun ON command: <ul style="list-style-type: none"> the  key (or the 3rd channel) to go to the down position (default) the  key (or the 1st channel) to go to the partial position 	
5.	The currently set response to the Sun ON command is confirmed with beeps: <ul style="list-style-type: none"> 2 long beeps – go to down position 4 long beeps – go to partial position 	
6.	The programming procedure ends automatically.	

Table A18 - BiDi-Awning - Setting response to Rain ON command		
N°	Description	Example
1.	Press the programming key of the already memorised transmitter.	
2.	Wait until you hear 2 beeps.	
3.	Press and hold the ▼ key (or the 3 rd channel) for 2 seconds until you hear 1 long beep.	
4.	Press the transmitter key to select response to the raining command: <ul style="list-style-type: none"> the ▼ key (or the 3rd channel) – go to the down position (default) the ▲ key (or 1st channel) – go to the up position 	
5.	Currently the set response to the rain ON command is confirmed with beeps: <ul style="list-style-type: none"> 2 long beeps – go to the down position 4 long beeps – go to the up position 	
6.	The programming procedure ends automatically.	





6.6 - Deleting transmitters

If memorised transmitters and settings need to be deleted, follow the steps from the table below:

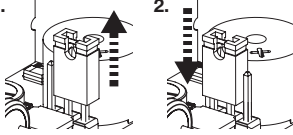

Table A19 - BiDi-Awning - Deleting single transmitter from memory		
N°	Description	Example
1.	Press 5 times the programming PRG key of the already memorised transmitter.	5x 
2.	The buzzer confirms with 5 beeps.	
3.	Press any key on the acquired transmitter to remove it from memory.	
4.	3 beeps confirm the correct removal.	
5.	If the device doesn't receive any signal for 10 seconds, the programming procedure ends automatically. You hear one long beep.	

6.7 - Factory reset

If the control unit needs to be reset to the factory settings (all transmitters and setting are deleted), follow the steps from the table below:

Table A20 - BiDi-Awning - Restoring to factory defaults with already memorised transmitter		
N°	Description	Example
1.	Press 5 times the programming PRG key of the already memorised transmitter.	5x 
2.	The buzzer confirms with 5 beeps.	
3.	Press the programming key.	
4.	5 beeps confirm a successful reset.	
5.	The reset procedure ends automatically and a long beep is heard. Afterwards, the control unit starts the start-up procedure according to Table A4.	

If the first memorized transmitter is inoperable, lost or isn't equipped with the programming PRG button, you can reset the control unit to the factory settings with not memorized transmitter. Follow the steps from the table below:

Table A21 - BiDi-Awning - Restoring to factory defaults with not memorised transmitter		
N°	Description	Example
1.	Switch the control unit off.	
2.	Change the position of the jumper from position 1 to position 2.	
3.	Power the control unit.	
4.	The buzzer confirms restoring to factory defaults with 5 beeps.	
5.	Remember to change the position of the jumper from position 2 to position 1 with disabled power.	

Note.

If the jumper position isn't changed to position 1, the device is blocked. After 10 seconds, it starts emitting a sound to inform the user that the process isn't finished.

7 PRODUCT DISPOSAL

This product is an integral part of the automation and therefore must be disposed together with the latter.
At the end of the product lifetime, the disassembly and scrapping operations must be performed by qualified personnel. This product is made of various types of material, some of which can be recycled while others must be scrapped. Seek information on the recycling and disposal systems envisaged by the local regulations in your area for this product category.

⚠ CAUTION! – Some parts of the product may contain pollutant or hazardous substances which, if disposed of into the environment, may cause serious damage to the environment or physical health.

⚠ CAUTION! – As indicated by the symbol alongside, disposal of this product in domestic waste is strictly prohibited. Separate the waste into categories for disposal, according to the methods envisaged by current legislation in your area, or return the product to the retailer when purchasing a new version.



⚠ CAUTION! – local legislation may envisage serious fines in the event of abusive disposal of this product.

8 DECLARATION OF CONFORMITY

Nice S.p.A. declares that the radio equipment type BiDi-Awning complies with Directive 2014/53/EU.
The full text of the EU Declaration of Conformity is available at: <http://www.niceforyou.com/en/support>



Nice S.p.A
Oderzo TV Italia
info@niceforyou.com

www.niceforyou.com